

The DIGITAL plus SILVER Mini locomotive decoder is suitable for all DC locomotives with continuous current draw of 0.5 Amp. or less. The characteristics of the decoder are:

Super smooth and silent high frequency back-emf motor control.
Asymmetric DCC support including directional stopping
Adjustable precision stopping control
Low speed gear for switching operations
Selectable for operation with 14/27, or 28/128 speed steps.
Operation on conventional DC layouts is possible or can be disabled.
Motor output = 0.5A continuous, 0.8A max, > 2 A stall.
Motor and function outputs protected
Two function outputs rated at 100mA each with advanced function mapping
Directional or independent lighting with dimming and special effects.
Support for Advanced Consist Control and Extended Addressing
Support for programming on the mainline (operations mode programming)
Support for all form of programming as described in NMRA RP-9.2.3
Supports service mode decoder lock
Size: L 0.43" x W 0.35"x H 0.11, L 11mm x W 9mm x H 2.8 mm (Mini-W)
L 0.43" x W 0.35"x H 0.13, L 11mm x W 9mm x H 3.3 mm (Mini-D)

Silver Mini Silent-Back EMF DCC Decoder

Art. no.° 10310.1
November 2006

Digital

plus
by Lenz®

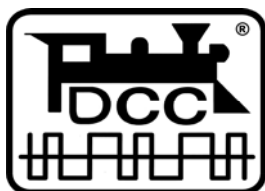

Lenz Silver decoders have received an NMRA C&I warrant. The Silver Mini decoder has been submitted for independent NMRA testing.

SILVER Decoder feature set

The following contains a short introduction of the features of the SILVER decoder as well as information on how to use them.

For more detailed information please refer to the "SILVER decoder" information which can be downloaded from the Lenz Elektronik GmbH website: www.lenz.com.

Capacity and protection equipment

The motor output has a current-carrying capacity of up to 1A without any concern for cooling! The short-term maximum current-carrying capacity is 1.8A. The decoder is protected against overloading, short circuits and overheating. In case of a fault, a bit is set in CV30 which will state the type of fault which has occurred. This bit can be cleared via setting this CV to 0. Because of this protection the Silver decoder can work with motors that have very high stall currents.

Maximum continuous current-carrying capacity of total decoder	0.5 Amps
Motor output - Continuous / maximum power / Stall	0.5 Amps / 0.8 Amps / NA
Function output A, and B	100 mA each

High Frequency Back EMF Motor control

Silver decoders have a very smooth and quiet high-frequency motor control (23kHz). If necessary, the performance of the decoder can be optimized to one of 6 specific motor types in the locomotive using CV50. These motor types include parameter sets which have been specially adapted to the respective models. In addition, it is possible to perform additional fine-tuning via CV113 or CV114 when selecting motor types 4 or 5. If desired you can switch off both the high-frequency drive as well as the control system itself. You can still use CV9 to adjust the repetition rate.

The minimum (CV2), maximum (CV5) and mid (CV6) speeds can be set; the decoder automatically adapts these desired speed parameters dynamically to ensure a steady, smooth curve. It is also possible to program a user defined unique speed curve.

The decoder also has what we refer to as a EMF switch which makes it possible to further adjust the decoder to different motor types. Depending on the motor type used, it is possible that a digitally controlled locomotive cannot reach an adequate maximum speed compared to a locomotive in conventional operation. If this is the case, activate your EMF switch by setting Bit 6 in CV 50. The locomotive will then reach a higher maximum speed while the minimum speed is also slightly increased.

Special Features

Function for disabling of acceleration and deceleration delay

Use function F4 (function assignment can be altered in CV59) to disable the acceleration and braking delay as well as the constant braking

distance during operation. The delays are disabled as long as the function is active.

Switching speed function

The switching speed halves the speed table. This facilitates particularly sensitive control during the switching process. Use function 3 (function setting, can be altered in CV58) to enable and disable the switching speed. If the shunting speed is enabled, the constant braking distance is disabled. The switching speed is enabled as long as the function is active

Constant braking distance

During the transition from an active speed step to speed step 0 (e.g. moving the speed control knob to the left limit-stop), the locomotive/train will travel a settable, pre-defined braking distance. This braking distance does not depend on the speed of the locomotive/train.

Enable the constant braking distance function (this requires setting Bit 0(1) in CV51. If this bit is not set, the decoder will use the normal speed-dependent braking delay).

The braking distance is defined by the value set in CV52. Since the motors and gear ratios of locomotives vary, the braking distance differs from locomotive to locomotive even if the same value is set in CV52.

Use a short test section to measure how long your locomotive's braking distance will be with a given value set in CV52. Start with the default value (100) in CV52.

Accelerate your locomotive until it has reached average speed.

At a chosen point in time, set the speed to 0. This requires moving the speed control to the stop position, if you are using the LH100, keep pressing the < key until the speed is set to 0 or until the locomotive address is displayed (if using the LH100, do not press key <>!). This result in a locomotive-specific emergency stop and the delays in the locomotive decoder will not be enabled!).

Measure the covered braking distance.

Increase or decrease the value in CV52, e.g. in steps of 10, and carry out another measurement. You will thus create a table which will indicate the braking distances in relation to the values set in CV52.

Important advice: The constant braking distance is only effective if the speed is changed to 0. If the speed is decreased from e.g. 28 to 10, the speed-dependent delay from CV4 becomes effective.

The constant braking distance is disabled while the switching speed function is switched on (default setting F3), or if the function to disable acceleration/deceleration is activated (default setting F4). Either of these two features can also be used if you wish to interrupt a constant braking process prematurely.

The constant braking distance does not function in analogue DC mode.

Mapping function outputs

Using function mapping (CVs 33-46) you can define which functions of the digital system are used to control the A and B function outputs. The A and B outputs can be allocated to function F0 (direction-dependent) or functions F1 to F8 as desired.

Lighting effect at function outputs

Special lighting effects can be assigned to each of the function outputs. The lighting effects for the function outputs A and B are set in CV60. If you wish to switch the effects with a function of the digital system, you can make the allocations to functions F1 to F8 in CV61 (for function outputs A and B). The effects available are shown in the CV table defined later in this manual.

Asymmetric DCC = Automatic Braking Control simple signal stop and slow approach

You can carry out a particularly simple stop at a signal using the ABC braking module. Depending on the signal position, this module creates an asymmetric track voltage in the braking section in front of the signal. The decoder reacts to this. Combined with the constant braking distance, precise on-the-spot stopping in front of red signals is not a problem. Of course, passage in the opposite direction is also possible. The signal indication "slow approach/caution" can be set using CV53.

You can operate all functions during the signal stop or slow approach – you can even reverse away again from the red signal! These special ABC modules can be used to assemble a very simple block section.

Activate the ABC control by setting Bit 2 (1) in CV51.

Push-pull train control

A push-pull train control can be set if the ABC braking module is used. There are two different options: push-pull operation with and without intermediate stops. The latter also takes slow-approach sections into account.

The push-pull train control is activated in CV51, Bit 4 (3) and Bit 5 (4). The stopping time at the end of the track is set in CV54 (1 to 255 sec).

Preparing to Install the Silver Mini Decoder:

A locomotive that runs well under DC will run exceptionally well under DCC. Replace worn out motor brushes and burned out light bulbs. Clean any dirt or oxidation from the wheels and pickups, and make sure that electrical contact is good. Now is also a good time to lubricate your locomotive.

Some advice on installing the decoder:

Although the SILVER decoder has many internal safeguards to prevent damage, you must not allow any metal part of the locomotive to touch the surface components of the decoder. This could cause a direct internal short circuit and the decoder will be destroyed. **The motor brushes**

MUST also be completely isolated from the rail pickup. Achieving isolation may require some different approaches on different locomotives, perhaps unsoldering wires or placing a thin piece of insulating plastic between the motor and the locomotive frame. If you have a VOM, check for infinite resistance between the motor and all the wheels. Take special note that a short might occur when the loco body is reinstalled.

DO NOT WRAP decoder with electrical tape or shrink wrap!

Doing so will impede air circulation and degrade the performance of the decoder. Instead, put electrician tape over any part of the locomotive frame or body that might touch the decoder and use double sided foam mounting tape to mount the decoder. This will prevent short circuits without 'suffocating' the decoder.

The SILVER decoder can not be set up for simultaneous use for 2-rail pickup and overhead cantenary or trolley operation. If the locomotive is turned the wrong way, the decoder could get twice the track voltage, which would destroy it!

Wiring Options

There are two wiring options for installing the SILVER, depending on how the locomotive is constructed. The functions could be connected with their common to the decoders floating common (blue wire) as shown below or one rail can be used as a common. A mixture of both options is also possible.

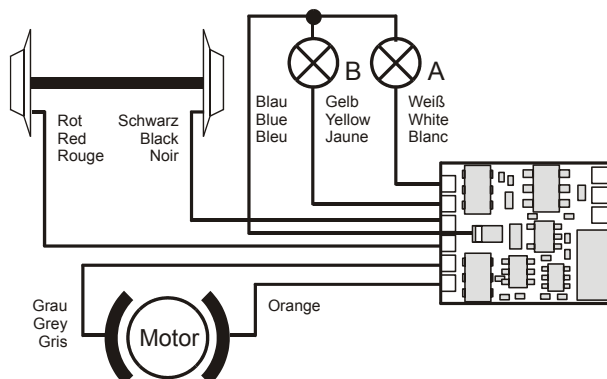

If the bulbs for the directional headlights are floating (isolated against wheel pick up and chassis) and connected according to above figure, they will shine brighter compared to using the rail as a common and the directional headlights will function while operating on conventional DC layouts.

Step by Step Installation for wired installation

The following instructions apply if you need to install the wired version. Two wires connect the decoder to the motor. Make sure that the motor is electrically isolated from both track pickups:

- Orange wire to the motor terminal that was previously connected to the right rail (Pin #1).
- Gray wire to the motor terminal that was previously connected to the left rail (Pin #5).

Two wires connect the decoder to the track electrical pickups:

- Red wire to right rail pickup (Pin #8).
- Black wire to the left rail pickup (Pin #4).

Three wires connect the headlights and functions to the decoder:

- White wire (Pin #6) to the forward headlight or the function controlled by Output A. If the bulb is isolated, connect the blue wire (Pin #7) to the other terminal.
- Yellow wire (Pin #2) to the rear headlight or the function controlled by Output B. If the bulb or function is isolated, then connect the blue wire (Pin #7) to the other terminal.

Note: The voltage of the function outputs is approximately the DCC track voltage. Many locomotives have 1.5 volt bulbs or LEDs. These must be protected by a resistor which has a typical value of between 500 ohms and 1 K ohms. For LEDs to light the Cathode must be connected to the White or Yellow wire

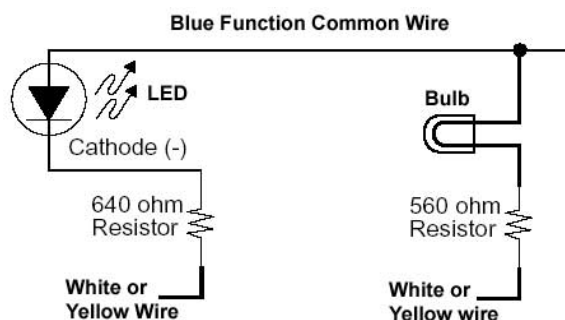

Place the locomotive (without its shell) on the programming track and read back the locomotive's address from the decoder. If the decoder is properly installed, you will be able to read back the factory pre-set address 03. Remove the locomotive from the track, and if necessary correct any wiring errors.

Installing the SILVER decoder via interface plug NEM652

These decoders come with a NEM651 / NMRA RP-9.1.1 small plug. This plug makes the installation of these decoders very simple.

To install the decoder simply remove the dummy plug in your locomotive and install the decoder plug. To ensure the headlights work correctly you must align the plug properly. Pin 1 of the plug connects to the orange wire. Ensure this is aligned to Pin 1 of the locomotive. If the plug is installed wrong way round the lights will not work.

When installing the plug ensure that the pins are not bent or broken.

Pin	Meaning
1	Motor connection 1
2	Motor connection 2
3	Right rail pickup
4	Left rail pickup
5	Function output A (front headlight)
6	Function output B (rear headlight)

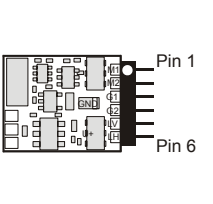

Testing the installation

Place the locomotive on the programming track (without its housing) and read the address. The decoder is programmed factory to the address 03. If you have connected the decoder correctly thus far, you should now be able to read the address. If you are not able to do so, it is possible that you have made a mistake when connecting the cables. Do not subject the locomotive to full running track power until you obtain the correct "03"

address read-out. Check the cable connections and change them as required. You should now be able to send your locomotive on its first test run on your layout.

Note: When you first turn on your system a blinking front and rear headlight indicates that the Silver decoder has identified a motor short. CV30 is set and the motor outputs are deactivated. If this condition occurs the fault should be corrected before you try to operate the decoder.

Configuring the Silver Decoder

The locomotive address, acceleration and deceleration delay, and all other features of the locomotive decoder can be changed as often as desired by reprogramming the decoder. The features are "stored" permanently in special locations even when the operational voltage is switched off. These locations are called "configuration variables" or simply "CV". The values are configured electronically, which means that it is not necessary to open the locomotive again after the decoder has been installed.

You can alter the content of CVs both through "Programming in operational mode (PoM)" (except for CV1, CV17 and CV18) or "Programming on the programming track".

For detailed instructions on how to program using the above-mentioned devices, please refer to the operating manuals which accompany those devices.

The decoder is programmed from the factory for operation with address 3 and 28 speed steps. The decoder can be used with these basic configurations immediately after purchase. All configurations can, of course, be changed.

Resetting the decoder to Factory Default

If you wish to reset all the decoder CVs to its factory setting, enter a value 33 or a value of 8 in CV8.

Please note: Some CVs (such as CV29) have specific meanings for each bit. The bit assignments in this table use a bit numbering scheme of 0-7 to correspond the NMRA convention for universal bit numbering. Many handhelds (such as the DIGITAL plus LH100 handheld) use a scheme of 1-8 to refer to the individual bits rather than 0-7. (Bit 0 in this table is displayed as a "1" on LH100 handheld, Bit 1 is identified as "2".) The bit numbers in () within these tables contain the LH100 bit numbers.

****Note:** in the range field the numbers in the [] are decimal.

Table of supported CVs

CV	Meaning	Range	Factory setting
1	Basic locomotive address. This number is the short address used to control the locomotive. When writing this CV, CV19 (consist address) is automatically cleared and CV29 Bit 6 (use of extended address) is deleted is set to 0.	1-127	3
2	Minimum starting voltage	0-255	0
3	Starting delay	0-255	6
4	Braking delay	0-255	5
5	Maximum speed	0-255	255
6	Mid speed Vmid (a value of 60 will give a linear curve)	0-255	48
7	Version number	-	76
8	Manufacturer's ID	-	99
9	Back EMF Repetition Rate	0-63	15
17	Extended locomotive address, high-order byte	192-231	192
18	Extended locomotive address, low-order byte	0-255	100
19	Consist address	1-127	0
29	Decoder Configuration, Byte 1:		6 (dec)
bit 0	Locomotive direction of travel:	0,1	0
(1)	0 = locomotive's direction is normal 1 = locomotive's direction is reversed	[1]	
bit 1	Headlight mode:	0,1	1
(2)	0 = Operation with 14 or 27 speed step systems.. 1 = Operation with 28, 55 or 128 speed steps. Note: your system must be set to the same mode.	[2]	
bit 2	Usage on conventional DC layouts:	0,1	1
(3)	0 = locomotive operates in digital mode only 1 = locomotive can operate on either conventional DC and on DCC	[4]	
bit 3	Not Used	0	0
(4)			
bit 4	Speed Curve Selection:	0,1	0
(5)	0 = factory pre-set speed curve is used 1 = user defined speed curve is used. Please enter the appropriate values into CV 67 to 94 before setting this bit.	[16]	
bit 5	Extended Addressing	0-1	0
(6)	0= Normal addressing 1= Four digit extended addressing	[32]	
bit 6 bit 7	always 0	0	0

30	Fault indication		0 (dec)
bit 0 (1)	= 1 Light short-circuit	0,1 [1]	0
bit 1 (2)	= 1 Overheating	0,1 [2]	0
bit 2 (3)	= 1 Motor short-circuit	0,1 [4]	0
CV	Function mapping for function outputs:		Factory setting
33	In order to allocate a function of the digital system to a function output, look for the section where the row of the desired function meets the column of the desired function output. Enter the number found in the respective CV. For the purpose of clarification, factory settings are shown in bold print.		
CV	Function output:	A	B
33	F0 forward	8	16
34	F0 backward	8	16
35	Function 1	8	16
36	Function 2	8	16
37	Function 3	8	16
38	Function 4	1	2
39	Function 5	1	2
40	Function 6	1	2
41	Function 7	1	2
42	Function 8	1	2
(*)-These values are not significant for SILVER 10410 and 10411.			
50	Motor configuration		0 (dec)
bits 0-3 (1-4)	Select motor type 0-5, enter as decimal number	0,1 [0-5]	0
Bit 5 (6)	=0 EMF switch inactive =1 EMF switch active	0,1 [32]	0
Bit 6 (7)	=0 Control switched <u>on</u> =1 Control switched <u>off</u>	0,1 [64]	0
Bit 7 (8)	=0 High-frequency motor control (approx. 23 kHz) =1 Low-frequency motor control (approx. 19 Hz)	0,1 [128]	0
51	Braking configuration		0 (dec)
bit 0 (1)	= 1 Constant braking distance activated	0,1 [1]	0
bit 1 (2))	= 1 ABC activated	0,1 [2]	0
bit 2 (3)	= 1 ABC direction-dependency <u>de</u> activated	0,1 [4]	0
bit 3 (4)	= 1 Activate push-pull operation without intermediate stop	0,1 [8]	0
bit 4 (5)	= 1 Activate push-pull operation with intermediate stop	0,1 [16]	0
bit 5 (6)	= 1 Stopping with DC independent of the polarity (only if Bit 3 is deleted in CV29).	0,1 [32]	
bits 6-7 (7-8)	Not used		0
52	Braking distance with activated constant braking distance	0-255	50
53	Slow approach with ABC	0-255	48
54	Stopping time in push-pull operation, 1 to 256 sec	0-255	4
55	Sets brightness at function outputs A, 255=max	0-255	255
56	Sets brightness at function outputs B, 255=max	0-255	255
57	Function mapping:		
-	Each bit of the CV stands for a function of the digital system: Bit 0(1) for function 1, Bit 1(2) for function 2 and so on up to Bit 7(8) for function 8. If you wish to allocate a function for dimming, the respective bit in CV 57 must be set.		
59			

57	Dimming function (no factory setting)	0-255	0
58	Switching speed function (factory setting F3)	0-255	4
59	acceleration and deceleration delay function (factory setting F4)	0-255	8
60	Lighting effect at function outputs A and B. The units digit of the value stands for function output A, the tens digit for function output B: 0 No effect 1 Marslight 2 Gyrolight 3 Strobe 4 Double strobe	0-255	0
61	Function mapping: lighting effect at function outputs A and B	0-255	0
67.. 94	Values for user defined speed table, default = factory speed curve	0-255	
105	User Identification #1	0-255	255
106	User Identification #2	0-255	255
112	Duration of motor timeout when track signal has stopped. $t = CV112 * 0.016sec$, default approx. 0.25 sec	0-255	16
113	Minimum PWM value, control for motor types 4 or 5	0-255	40
114	Change duty cycle for motor type 4 or 5	0-255	10
115	Asymmetric DCC sensitivity	6-30	12
128	Decoder Software Version – read only		3

North American Warranty

Lenz GmbH does everything it can do to ensure that its products are free from defects and will operate for the life of your model railroad equipment. From time to time even the best engineered products fail either due to a faulty part or from accidental mistakes in installation. To protect your investment in Digital plus products, Lenz GmbH offers a very aggressive 10 year Limited Warranty.

This warranty is not valid if the user has altered, intentionally misused the Digital Plus product, or removed the product's protection, for example the heat shrink from decoders and other devices. In this case a service charge will be applied for all repairs or replacements. Should the user desire to alter a Digital Plus Product, they should contact Lenz GmbH for prior authorization.

Year One: A full repair or replacement will be provided to the original purchaser for any item that that has failed due to manufacturer defects or failures caused by accidental user installation problems. Should the item no longer be produced and the item is not repairable, a similar item will be substituted at the manufacturer's discretion. The user must pay for shipping to an authorized Lenz GmbH warranty center.

Year 2 and 3: A full replacement for any item will be provided that has failed due to manufacturer defects. If the failure was caused by accidental user installation or use, a minimal service charge may be imposed. Should the item no longer be produced and the item is not repairable, a similar item will be substituted at the manufacturer's discretion. The user must pay shipping to and from the authorized Lenz GmbH warranty center during this portion of the warranty period.

Year 4-10: A minimal service charge will be placed on each item that has failed due to manufacturer defects and/or accidental user installation problems. Should the item no longer be produced and the item is not repairable, a similar item will be substituted at the manufacturer's discretion. The user must pay shipping to and from the authorized Lenz GmbH warranty center during this portion of the warranty period.

Please contact your dealer or authorized Lenz GmbH warranty center for specific instructions and current service charges prior to returning any equipment for repair.

Hüttenbergstraße 29
35398 Gießen, Germany
Hotline: 06403 900 133
Fax: 06403 900155
info@digital-plus.de

Lenz
ELEKTRONIK GMBH
<http://www.lenz.com>

Lenz Agency of North America
PO Box 143
Chelmsford, MA 01824
ph: 978 250 1494
fax: 978 455 LENZ
support@lenz.com

This equipment complies with Part 15 of FCC Rules. Operation is subject to the following two conditions: (1) this device may not cause harmful interference, and (2) this device must accept any interference received, including interference that may cause undesired operation.

CE Please save this manual for future reference!

Not suitable for children under three because of the danger of swallowing the small constituent pieces. Improper use can result in injury from functionally necessary points and edges

© 2005 Lenz GmbH, All Rights Reserved